

Headspace Samplers

HS-20 Series

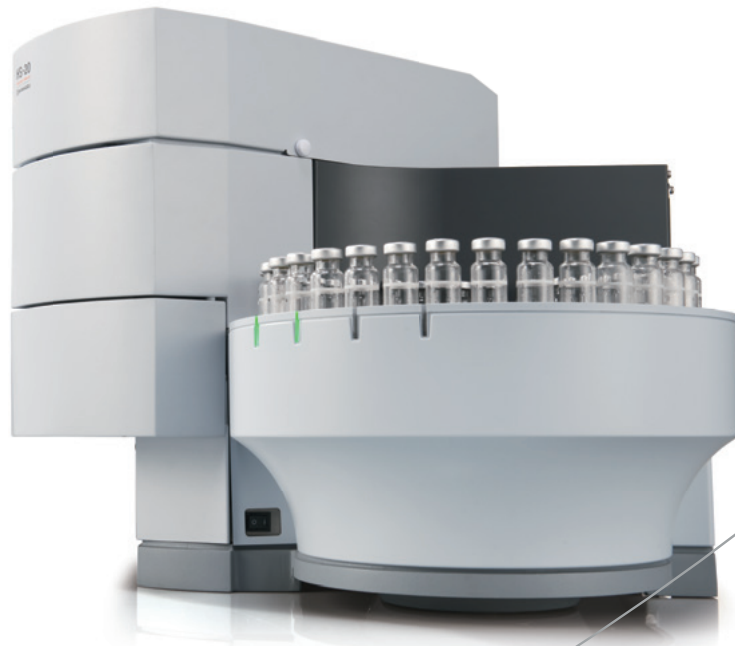

HS-20 Series of Headspace Samplers

A Revolutionary System Aimed at Performance and Ease of Use

The HS-20 Series is the optimal solution for volatile component analysis.

Its superior performance and user-friendly design support all types of analyses, from research to quality control.



1 Performance

High repeatability and low carryover ensure reliable quantitation. In addition, an oven with a maximum temperature of 300 °C enables analysis of high-boiling compounds.

2 User-Friendly Design

Easily place samples in the tray with the user-friendly design. Also, the needle, sample loop, trap, and other consumables can easily be replaced from the top of the instrument.

3 Ease-of-Operation

An easy-to-learn user interface and flexible settings help prevent operating errors. An audit trail function that records a history of method changes and a function that records leak test results assist in tracing the causes of unexpected results.

4 Flexibility

With the trap model, concentrating the headspace gas enables the analysis of ultra-trace components, such as gases released from parts and materials. The optional barcode reader enables samples to be controlled via a chromatography data system.

5 Productivity

An ECO mode and shutdown function help minimize gas and power consumption. Hydrogen can also be used safely as the carrier gas.

Performance

High Repeatability

The HS-20 Series achieves high repeatability through both high-accuracy flow rate control via the pneumatic flow controller (Advanced Flow Control: AFC system) and a mechanism that allows the sample vial to enter the oven from the bottom. Consequently, this system minimizes heat loss, and maintains high thermal stability during overlap analyses.

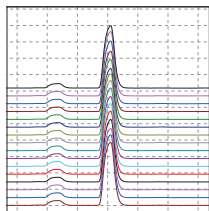

Methanol 50 ppm
repeatability (n = 20)
1.5 %

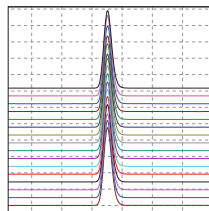

n-Butanol 50 ppm
repeatability (n = 20)
1.5 %

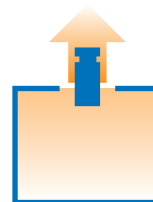

Typical HS Sampler
Internal heat easily escapes
during vial transfer,
temporarily reducing the
oven temperature.



HS-20
Conveyance from the
bottom makes it difficult
for heat to escape from
inside, improving oven
temperature stability.
(Patent US 8806965)

Low Carryover

Keeping the sample line inert and as short as possible results in extremely low carryover. No residue is left, even with acetic acid and other polar compounds, enabling highly reliable analysis. (Patent US 8584507)

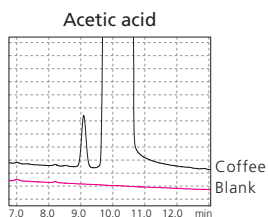

Residual acetic acid in coffee
< 0.0001 %

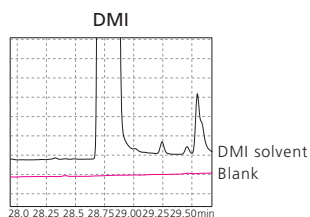

Residual DMI solvent
< 0.0001 %

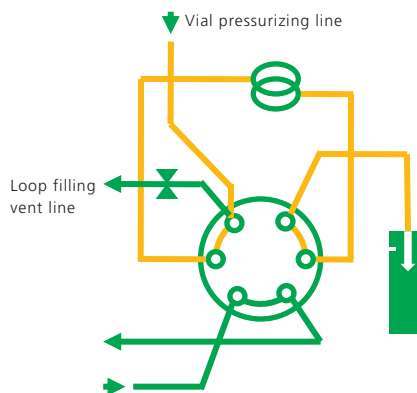

High-Temperature Compatibility

With an oven configurable up to 300 °C and a short, inert sample line, the HS-20 Series allows the analysis of high-boiling compounds.

Cyclic siloxane is a raw silicone material, trace quantities of which remain in oils, liquid rubber, and other products. Because cyclic siloxane is volatile, it could potentially cause problems with contacts in electronic parts, so controlling its concentration is very important. The HS-20 Series makes it possible to measure everything from cyclic siloxane to phthalate esters under the same conditions.

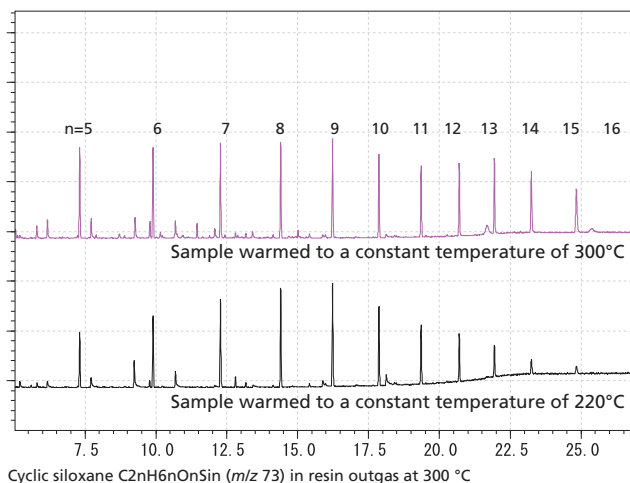

User-Friendly Design

User-Friendly Sample Tray

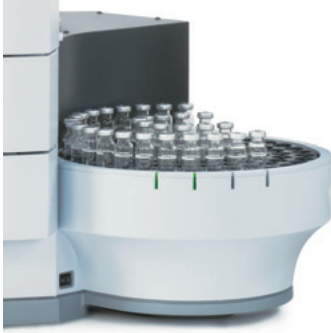

The HS-20 sample tray is 20 cm higher than the desk, enabling it to be seen at all times. This makes sample placement easy.

In addition, 10 mL and 20 mL vials can be placed and analyzed simultaneously without the need for special adapters.

Furthermore, the optional barcode reader allows samples to be controlled using barcodes.



Analysis of blood and other samples in the forensic field requires a system that not only offers excellent performance, but also eliminates operational errors.

With its user-friendly design, the HS-20 Series prevents mistakes, while the barcode reader records logs to dramatically improve traceability.



Visit	Barcode	Result	Method File	Injection Time
37	ABCD013633	Normal end	HS20\Method\BCRtest.htm	2/24/2012 5:26:01 PM
38	ABCD010139	Normal end	HS20\Method\DCRtest.htm	2/24/2012 5:26:50 PM
39	ABCD013633	Normal end	HS20\Method\BCRtest.htm	2/24/2012 5:28:43 PM
40	ABCD010139	Normal end	HS20\Method\BCRtest.htm	2/24/2012 5:30:37 PM
41	ABCD013633	Normal end	HS20\Method\BCRtest.htm	2/24/2012 5:32:27 PM
42	ABCD010139	Normal end	HS20\Method\DCRtest.htm	2/24/2012 5:34:16 PM
43	ABCD013633	Normal end	HS20\Method\BCRtest.htm	2/24/2012 5:36:06 PM
44	ABCD010139	Normal end	HS20\Method\BCRtest.htm	2/24/2012 5:37:56 PM

Quantitative Results Browser

Easy Maintenance

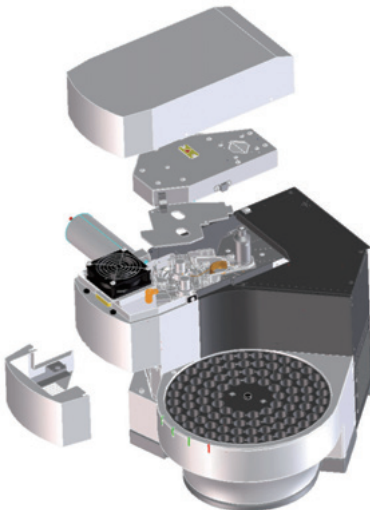

The HS-20 Series has been designed to enable sample loop and needle replacement and other maintenance work to be performed easily from the top of the instrument.

Even if sample lines become contaminated by high-concentration samples, the tubing alone can be replaced.

Also, the capillary column fittings are identical to those used in the GC injection port, enabling easy column replacement.

Consumable Usage Counter records the number of uses for each part and reports when it reaches a set number.

This superior design minimizes downtime during maintenance and improves laboratory productivity.

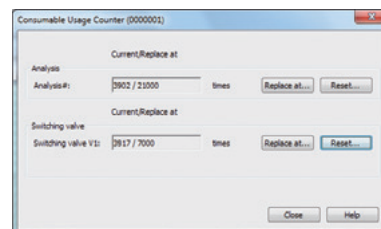

Consumable Usage Counter

Ease-of-Operation

Usability

Operating the HS-20 does not require concurrently operating multiple software programs. The HS-20 can be used by simply specifying the HS-20 unit in configuration settings for the GC or GC-MS control software. Due to a user interface with the same look and feel as the GC and GC-MS method settings, operating the headspace sampler is extremely easy to learn.

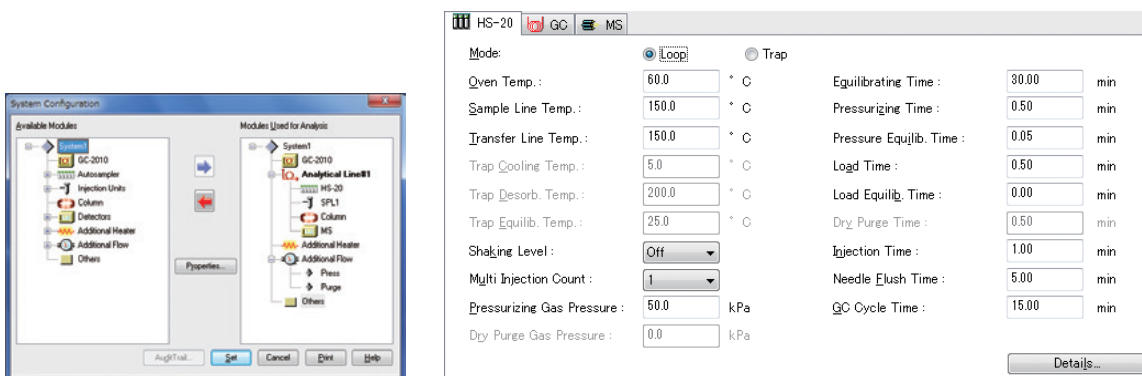

Traceability

The GCMSsolution™ GC-MS control software and LabSolutions™ LC/GC GC control software support compliance with FDA 21 CFR Part 11.

The audit trail function records a history of all changes made to HS-20 methods, so that they can be reviewed later.

Because the system records the internal vial pressures and leak test results prior to sampling in analytical results, it is easy to trace the cause of any unexpected results.

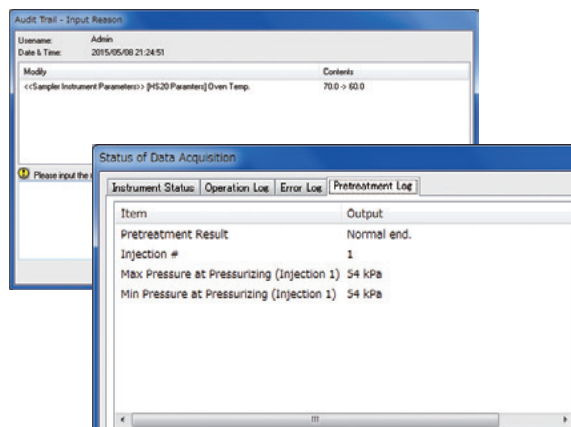

Flexibility

If the operator forgets to place a vial in the sample tray or a leak error occurs due to an improperly sealed vial, the system allows the operator to select whether to stop the continuous analysis or skip the applicable vials. That helps prevent wasting valuable time because of simple mistakes.

It also allows the operator to select whether to switch ON/OFF the function that checks for blockage by measuring the needle resistance during each analysis, or select the actions to take in the event the barcode reader fails to read a vial.

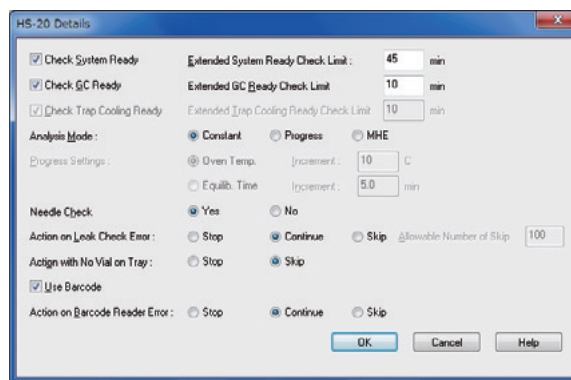

Flexibility

Sample Concentration

The HS-20 trap model is equipped with electronic trap cooling that concentrates the headspace gas, enabling detection of volatiles at lower concentrations. By using hydrophobic TENAX®, the trap enables the analysis of low-boiling compounds by concentrating them to high-boiling compounds in samples containing moisture.

Method files make it easy to switch between trap and conventional modes, in which a sample loop is used. The two modes can be combined even in continuous analysis via batch processing.

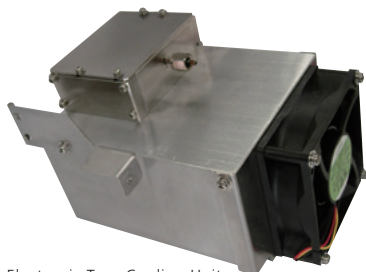

Electronic Trap Cooling Unit

Start Vial #	End Vial #	Analysis Mode	Method File Path	Comment
1	10	Regular Analysis	HS20\Method\FVOC LoopMode001.hsm	
2	11	Regular Analysis	HS20\Method\FVOC TrapMode001.hsm	
3	21	Regular Analysis	HS20\Method\FVOC LoopMode001.hsm	
4	31	Regular Analysis	HS20\Method\FVOC TrapMode001.hsm	

Switching Between Loop Mode and Trap Mode Using Batch Editor

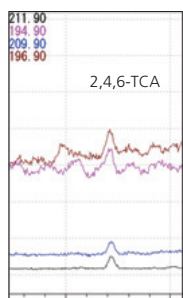

1ppt TCA in Wine (Loop mode)

Area x 4
S/N x 10

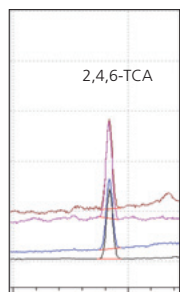

1ppt TCA in Wine (Trap mode)

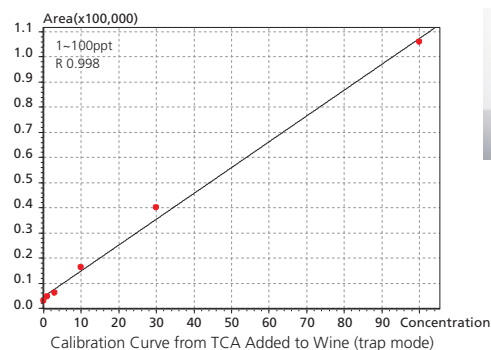

Calibration Curve from TCA Added to Wine (trap mode)



High-Sensitivity Analysis of Fragrance Components in Coffee

In combination with a GCMS, concentration of analytes on the trap enables qualitative and quantitative analyses of fragrance components at trace levels undetectable with a conventional headspace sampler.

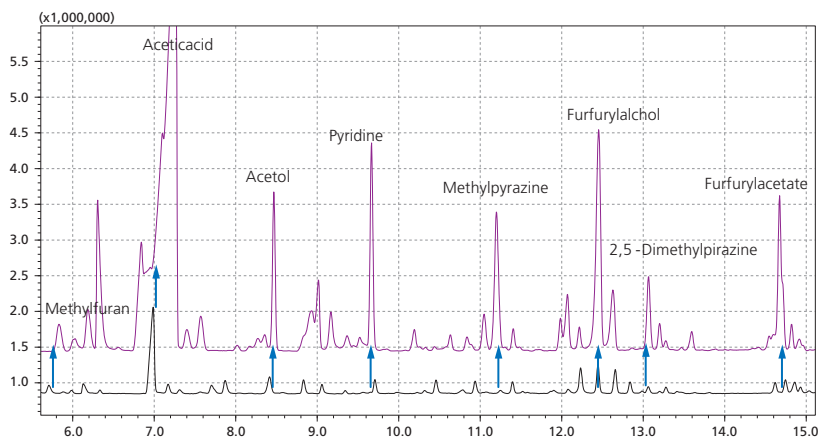

Peak areas are improved 5 to 50 times.



HS-20 + GCMS-QP2020 NX

Productivity

Hydrogen Can Be Used as Carrier Gas

The carrier gas in HS-20 samplers is independent of the vial pressurization gas, which allows the user to safely use more economical hydrogen gas. In the event a leak is detected, the carrier gas is automatically shut OFF to minimize any risk of ignition or explosion. Hydrogen gas is supplied from a safe high-purity hydrogen gas generator, rather than a gas cylinder, which can involve many restrictions depending on the installation site.

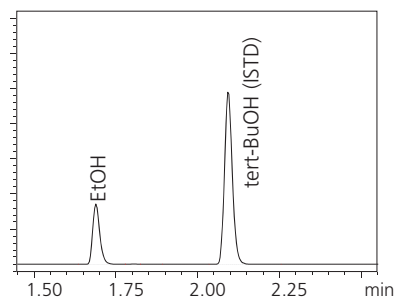
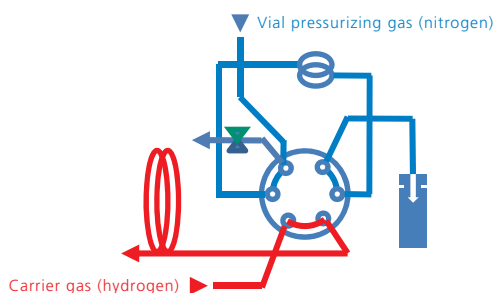

Results from Measuring Alcohol in Blood Using Hydrogen Carrier Gas

Eco-Friendly

GC and GC-MS systems can be shut down or gas flow rates reduced automatically after finishing continuous analyses, even if an HS-20 sampler is connected to the system. It also allows running costs and environmental impacts to be minimized by reducing the heater power when not in use.

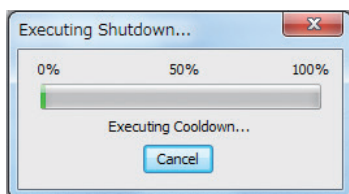

Compatibility

The HS-20 includes drivers that allow you to control the sampler using Waters Empower™ software.

Parameter settings can be specified via the instrument method edit window in Empower, which allows even first-time users of Shimadzu products to operate the HS-20 with confidence.

In addition to monitoring values for the gas flow rate, gas pressure, and respective temperatures, the control panel also displays setting values, which makes it easy to confirm the instrument status.

The ability to overlap the vial heating steps during continuous analyses helps increase analysis efficiency.

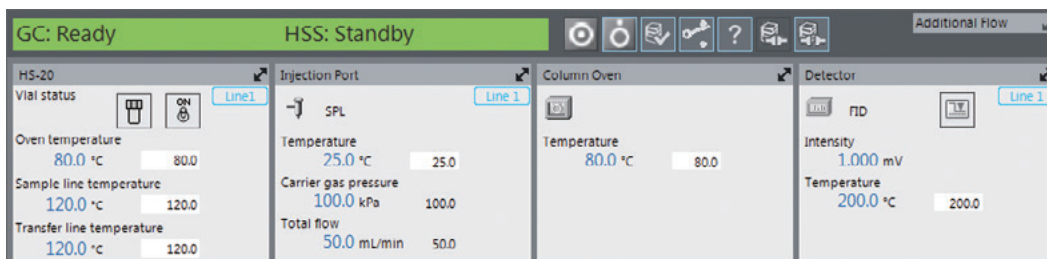

Empower 3 Control Panel

Batch Analysis of VOCs in Wastewater

With its high thermal stability and inert sample pathway, the HS-20 Series can measure VOCs in wastewater with high repeatability. Carryover is minimal, so the entire sample tray, which is capable of holding 90 samples, can be effectively utilized.

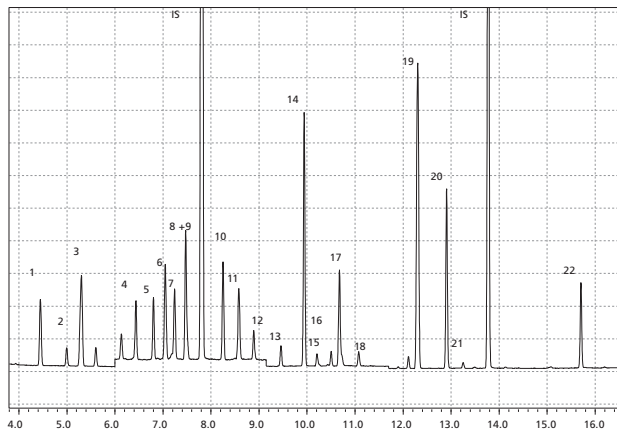

VOC 0.1 ppb reproducibility RSD% (n = 5)

1	1,1-Dichloroethene	1.8	12	Bromochloroethane	2.0
2	Dichloromethane	3.0	13	cis-1,3-Dichloropropane	1.8
3	trans-1,2-Dichloroethene	1.4	14	Toluene	1.4
4	cis-1,2-Dichloroethene	2.8	15	trans-1,3-Dichloropropane	1.8
5	Chloroform	2.3	16	1,1,2-Trichloroethane	2.9
6	1,1,1-Trichloroethane	1.7	17	Tetrachloroethene	0.8
7	Carbon tetrachloride	2.2	18	Dibromochloromethane	2.1
8	1,2-Dichloroethane	2.7	19	m+p-Xylene	1.7
9	Benzene	0.7	20	o-Xylene	1.4
10	Trichloroethene	1.2	21	Bromoform	2.3
11	1,2-Dichloropropane	3.1	22	1,4-Dichlorobenzene	1.2

Aqueous Solution of USP<467> Class 2A/2B Pharmaceutical Residual Solvents

In combination with a robust GC detector, the system can be used for quality control requiring high quantitative accuracy. Traceability is guaranteed by the all-sample leak check function and the digitized log function.

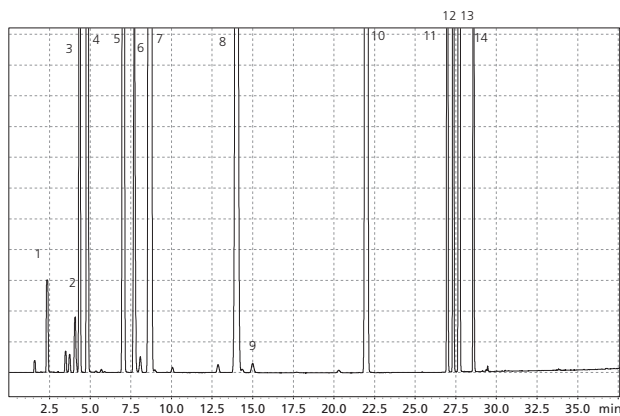

Reproducibility of USP<467> Class 2A/2B Procedure A (Aqueous Solution)

Compound	RSD% (n=20)	
2	Acetonitrile	1.1
3	Dichloromethane	1.7
4	trans-1,2-Dichloroethene	2.3
5	cis-1,2-Dichloroethene	1.9
6	THF	0.6
10	Toluene	2.5
11	Chlorobenzene	2.5
18	1,2-Dimethoxyethane	3.1
20	Pyridine	2.6

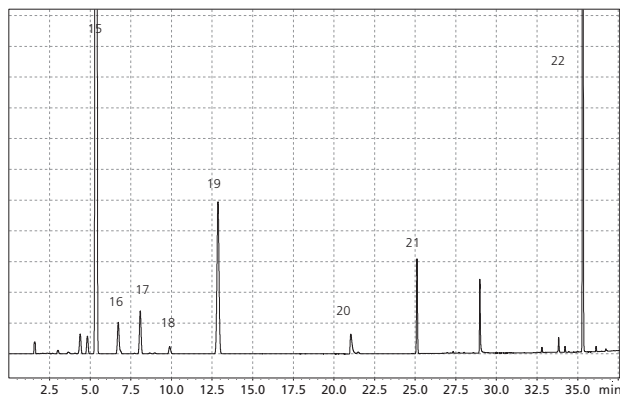

HS-20 + Nexis GC-2030

Simultaneous Analysis of Odor Components in Beer at Room Temperature

The HS-20 equilibration oven temperature can be set as low as 35 °C, which allows measuring odor components in beer that increase in concentration at temperatures above room temperature.

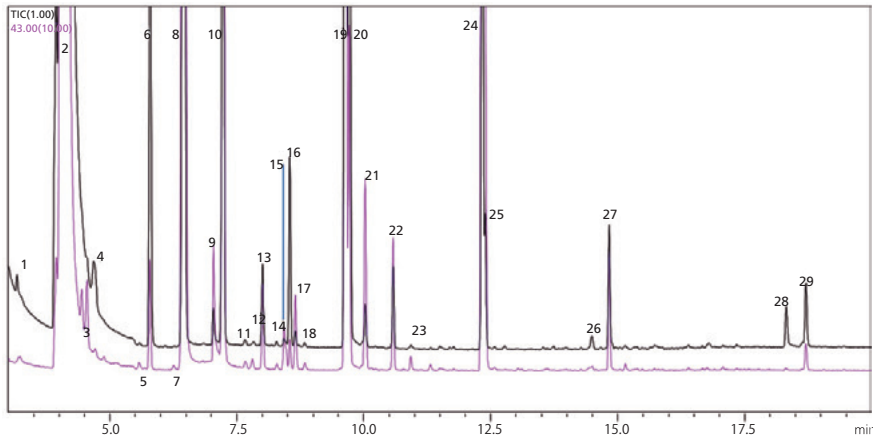

1 Methanol	9 Acetic acid	17 Propyl acetate	25 2-Methylbutyl acetate
2 Ethanol	10 Isobutyl alcohol	18 2,4,5-Trimethyl-1,3-dioxane	26 2,2-Dimethyldecane
3 Acetone	11 Isovaleraldehyde	19 Isopentyl alcohol	27 Caproic acid ethyl ester
4 Dimethyl sulfide	12 3-Methyl 2-butanone	20 2-Methyl-n-butanol	28 Phenylethyl Alcohol
5 Isobutyl aldehyde	13 1-Butanol	21 Isobutylacetate	29 Caprylic acid ethyl ester
6 1-Propanol	14 2,5-Dimethylfuran	22 Butyl butanonate	
7 2,3-Butanedione	15 2,3-Pentanedione	23 Butyl acetate	
8 Ethyl acetate	16 Ethyl propanoate	24 Isoamyl acetate	

Analysis of Alcohol in Blood

The content of ethanol and other alcohols or oxygenated compounds in blood is often analyzed in forensics, emergency medicine, and other fields. For such applications, a GC-FID system configured with a headspace sampler is used.

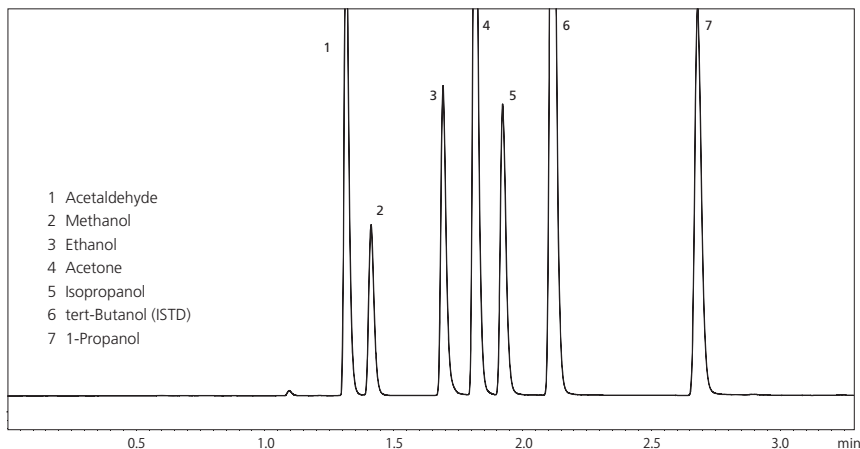

1 Acetaldehyde
2 Methanol
3 Ethanol
4 Acetone
5 Isopropanol
6 tert-Butanol (ISTD)
7 1-Propanol

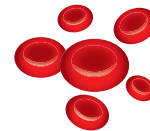

Repeatability of 0.1 mg/mL ethanol
RSD% (n = 7)
0.6 %

Ultra Fast Analysis of VOCs by GC-MS/MS

Up to eight samples per hour can be analyzed using a GC-MS/MS system with a high degree of selectivity.

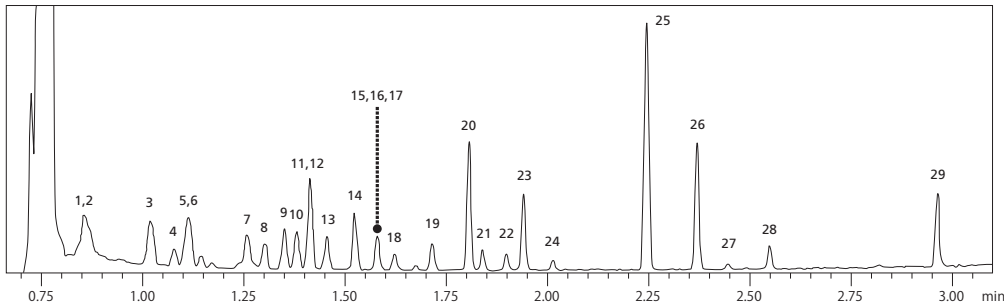

- | | |
|----------------------------|--------------------------------|
| 1 Vinyl chloride-d3 (ISTD) | 16 1,2-Dichloropropane |
| 2 Vinyl chloride | 17 1,4-Dioxane |
| 3 1,1-Dichloroethene | 18 Bromodichloromethane |
| 4 Dichloromethane | 19 cis-1,3-Dichloropropane |
| 5 MTBE | 20 Toluene |
| 6 trans-1,2-Dichloroethene | 21 trans-1,3-Dichloropropane |
| 7 cis-1,2-Dichloroethene | 22 1,1,2-Trichloroethane |
| 8 Chloroform | 23 Tetrachloroethene |
| 9 1,1,1-Trichloroethane | 24 Dibromochloromethane |
| 10 Carbon tetrachloride | 25 m,p-Xylene |
| 11 1,2-Dichloroethane | 26 o-Xylene |
| 12 Benzene | 27 Bromoform |
| 13 Fluorobenzene (ISTD) | 28 4-Bromofluorobenzene (ISTD) |
| 14 Trichloroethene | 29 1,4-Dichlorobenzene |
| 15 1,4-Dioxane-d8 (ISTD) | |

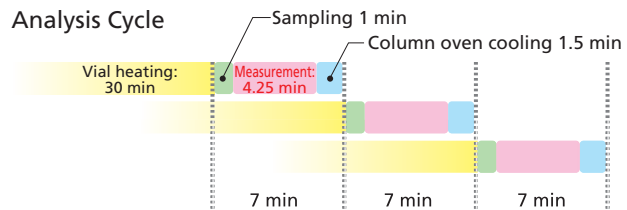

HS-20 Trap + GCMS-TQ8040 NX

Multiple Headspace Extraction

Solid samples, such as macromolecular polymers, are normally measured by dissolving them in a solvent before injection into the GC unit. But selecting the solvent and dissolving the sample is time-consuming and insoluble samples cannot be measured. However, using the multiple headspace extraction (MHE) method allows estimating the concentration of target components in solid samples based on the target component peak area attenuation curve obtained by repeatedly analyzing the headspace from sealed vials of the crushed sample. The MHE method is used as a residual monomer measurement method that does not require any tedious pretreatment processes, such as dissolving samples in solvent.

Measurement Procedure

1. Seal a standard sample in an HS vial.
2. Weigh the standard sample and seal it in an HS vial.
3. Analyze the standard and target sample at least 3 times each.
4. Determine the sample content by calculating the area value for the zeroth analysis based on the trend in standard and target sample area values.

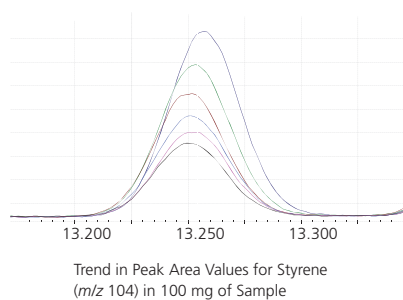

Estimated content of styrene in sample:
 $10 \text{ mg (STD)} / 445966.8942 \times 40255.4227$
 = 0.90 mg

STD	Area(m/z 104)	Ln(2)Area
Calc	445966.8942	13.008
Run1	369783	12.82067163
Run2	296082	12.59839172
Run3	233387	12.3604533
Run4	188961	12.14929592
Run5	156137	11.95848911
Run6	132033	11.79080717

Sample	Area(m/z 104)	Ln(2)Area
Calc	40255.4227	10.603
Run1	36114	10.49443588
Run2	32599	10.39203689
Run3	30040	10.31028511
Run4	27794	10.23257545
Run5	24295	10.09802585
Run6	21662	9.98331485

Specifications and Installation Conditions

Model	HS-20	HS-20Trap	HS-20LT
Transfer line	Short (350 °C)	Short (350 °C)	Long (200 °C)
Trap	No	Yes	No



Sample Injection Method	SilcoTek Sulfinert® sample loop 1 mL (standard); 0.2 mL, 3 mL (optional) or trap (HS-20Trap)
Number of Vials	90
Vials	Outer dia. 22.5 mm x 79 mm (20 mL); outer dia. 22.5 mm x 46 mm (10 mL); can be combined
Vial Mixing	5 stages max.
Leak Check	All-vial automatic check
Optional Barcode Reader	Optional, can read 6 types of barcodes
Vial Warming Temperature	Room temperature + 10 to 300 °C (Settings are 0 to 300 °C, in 1 °C units, with an accuracy of ±0.1 °C)
Vial Incubator Capacity	12 vials heated independently in overlapping mode
Sample Line Temperature	Room temperature + 10 to 220 °C or 150 to 300 °C (set in 1 °C units, accuracy of ±0.5 °C) Long transfer line model (HS-20LT): Room temperature + 10 to 220 °C
Transfer Line Temperature	Room temperature + 10 to 350 °C (set in 1 °C units, accuracy of ±0.5 °C) Long transfer line model (HS-20LT): Room temperature + 10 to 200 °C
Trap	Inner dia. 2 mm x 100 mm, Sulfinert tube Filler TENAX TA (standard), Sigma-Aldrich Carboxen™ + Carboxen® (optional)
Trap Cooling Temperature	-30 to 80 °C (set in 1 °C units, accuracy of ±1 °C) For a sample line at 250 to 300 °C, room temperature - 30 °C For 150 to 250 °C, room temperature - 40 °C For 150 °C or less, room temperature - 50 °C
Trap Heating Temperature	0 to 350 °C (set in 1 °C units, accuracy of ±1 °C)
Carrier Gas Control	Electronic control via AFC built into GC
Vial Pressurized-Gas Control	Electronic control via APC built into GC
Carrier Gas	High-purity helium, nitrogen or hydrogen
Vial Pressurizing and Purge Gas	High-purity helium, nitrogen
PC Interface	USB
Control Software	Operates collectively with LabSolutions LC/GC or GCMsSolution (FDA CFR 21 Part 11 compliant) Waters Empower3 Software Driver, Thermo Scientific Dionex™ Chromeleon™ 6.8 Software Driver
Software Operating Environment	Windows® 7/10 (32/64 bit)
Guaranteed Operating Environment	15 to 30 °C, humidity up to 70 % RH (performance guaranteed at 18 to 28 °C with temperature fluctuations within ±1.3 °C)
Power Supply	1200 VA max. (HS-20, HS-20LT), 1500 VA max. (HS-20Trap)
Dimensions	W553 mm x H430 mm x D543 mm, excluding PC
Weight	33 kg (HS-20, HS-20LT), 40 kg (HS-20Trap)

Dimensions (HS-20Trap + GCMS-QP2020 NX)

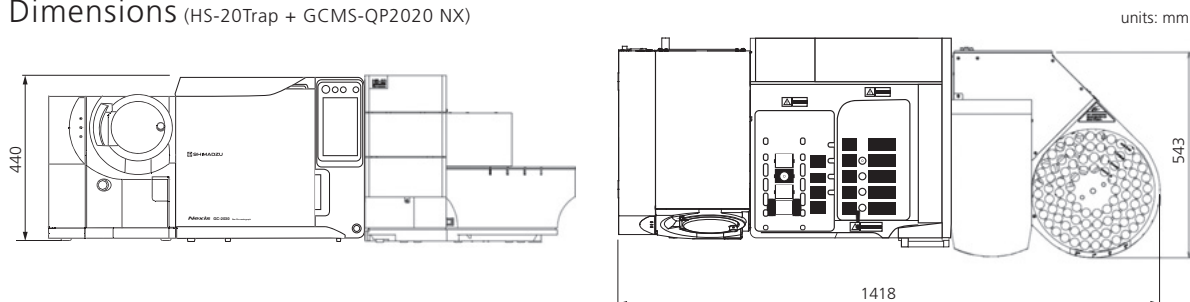

GCMSsolution, GCMS-TQ, Nexis, and LabSolutions are trademarks of Shimadzu Corporation.
Sulfinert is a registered trademark of SilcoTek Corporation.
Carbopack is a trademark of Sigma-Aldrich Co. LLC.
Carboxen is a registered trademark of Sigma-Aldrich Co. LLC.
Dionex and Chromeleon are trademarks of Dionex Corporation.
TENAX is a trademark of BUCHEM B.V.
Empower is a trademark of Waters Technologies Corporation.
Windows is either registered trademarks or trademarks of Microsoft Corporation in the United States and/or other countries.



Shimadzu Corporation
www.shimadzu.com/an/

For Research Use Only. Not for use in diagnostic procedures.

This publication may contain references to products that are not available in your country. Please contact us to check the availability of these products in your country.

Company names, products/service names and logos used in this publication are trademarks and trade names of Shimadzu Corporation, its subsidiaries or its affiliates, whether or not they are used with trademark symbol "TM" or "®".

Third-party trademarks and trade names may be used in this publication to refer to either the entities or their products/services, whether or not they are used with trademark symbol "TM" or "®".

Shimadzu disclaims any proprietary interest in trademarks and trade names other than its own.

The contents of this publication are provided to you "as is" without warranty of any kind, and are subject to change without notice. Shimadzu does not assume any responsibility or liability for any damage, whether direct or indirect, relating to the use of this publication.